

max roller projection: 10mm



silicone lip projection: 5mm (±1mm)

NOTE :

When specifying this drop seal with a FritsJurgens System M or M+ Pivot hinge, a minimum of 6mm is required between the face of the bottom pivot body to the face of the drop seal profile in order to avoid having the silicone collide with the pivot floorplate when the drop seal deploys.

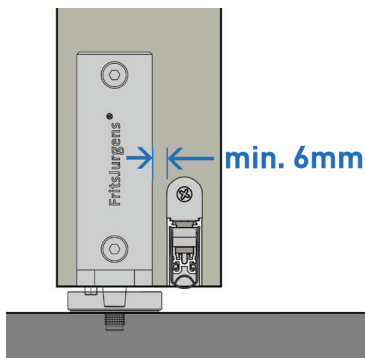

Schall-Ex® L-15/30 WS PIVOT

FEATURES :

- automatic drop seal for pivot doors
- profile: 15x30, anodized aluminum
- single-actuating roller, max. protusion 10mm
- inverted/upward actuation possible
- sound reduction of 50dB over a 12mm gap
- parallel actuation & self-levelling mechanism
- maximum seal travel: 20mm
- seal profile: silicone, self-extinguishing
- seal color: grey
- standard lengths (below) can be reduced up to 125mm (<5")
- engineered and manufactured in Germany
- ships with all necessary fasteners

NOTE : optional standard satin stainless steel flat jamb strike (model 8117) available to ship as a set with this drop seal. Add "8117" to the model numbers below (e.g. 1-946-0762-8117).

model no.	overall length
1-946-0762	25"—30" (635—762 mm)
1-946-0889	29-7/8"—35" (759—889 mm)
1-946-1016	34-7/8"—40" (886—1016 mm)
1-946-1143	39-3/4"—45" (1010—1143 mm)
1-946-1270	44-5/8"—50" (1133—1270 mm)
1-946-1397	49-5/8"—55" (1260—1397 mm)
1-946-1524	54-1/2"—60" (1384—1524 mm)
1-946-1651	59-1/2"—65" (1511—1651 mm)
1-946-1778	64-3/8"—70" (1635—1778 mm)
1-946-1905	69-1/4"—75" (1759—1905 mm)
1-946-2000	74-1/4"—78-3/4" (1886—2000 mm)

custom lengths available upon request

Bridgeport Worldwide does not accept any responsibility for misprints and subsequent specification changes although every effort has been made to avoid any errors during preparation of this document.